

QUICK GUIDE



# SNP141 License Plate Recognition



## Device Interface Description



No.	Function	Label	Description
1	Power	DC 12V; GND	Standard 12VDC 3A
2	Light indicator	SYS (Green)	Flashing means the system is currently working properly, whereas continuous on or off means starting or abnormal.
3	SD Card Slot	TF-CARD	SD card slot, maximum 256GB
4	Network Interface (RJ45 LAN1)	RJ45/LAN 1	Supports 10/100Mbps Ethernet transmission.
5	Network Interface (RJ45 LAN2)	RJ45/LAN 2	Support 10/100/1000Mbps Ethernet transmission. (For Aux. LPR Camera only)
6	Serial Port (RS485-1)	A1/B1	Connect to LED Display.
7	Serial Port (RS485-2)	A2/B2	Spare
8	Output terminal (Alarm Out)	OUT1/OUT2/ OUT3/OUT4	Can be used for barrier gate opening.
9	Input terminal (Alarm In)	IN1/2/3/4 /GND	Can be connected to grounded sensing coils for external signal triggering and capturing images.
10	Reset	RESET	Press for 5 to 10 seconds for a long time, and the equipment will fully restore to factory configuration.

## Equipment Installation

### LPR Camera Installation

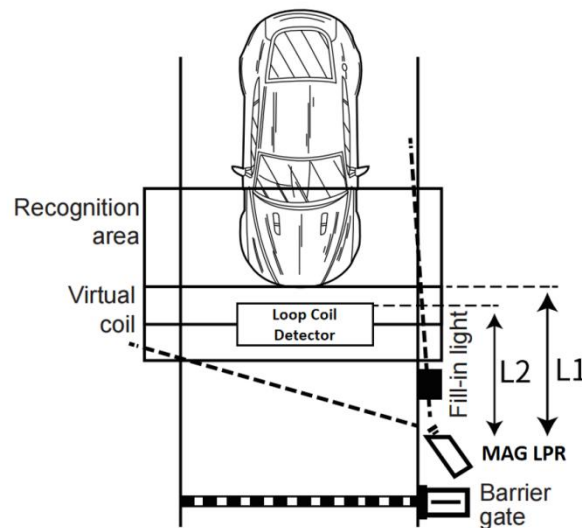

Fig. 1: Installation Diagram of LPR Camera

#### Installation Requirements

1. Install in front of the barrier gate.
2. About **3 - 6m** from the virtual coil (**L1**).
3. About **3 - 4m** from the loop detector (**L2**).
4. The **pitching angle of camera & fill light** is installed is recommended to be between **15° - 40°** and as far as possible.

### LED Fill Light Installation

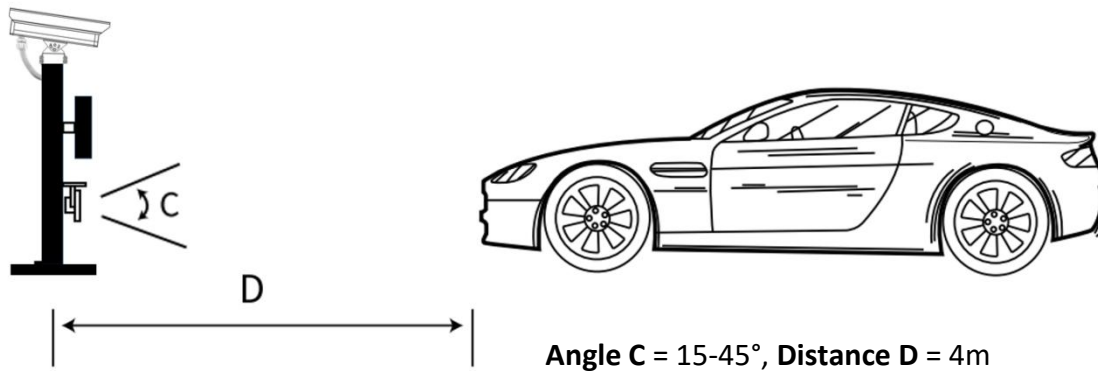

Fig. 2: Installation diagram of LED Fill Light

### Installation Requirements:

- Distance, D: The recommended distance between the fill light and license plate is around 4m.
- Angle, C: The fill light should be angled so that it illuminates the license plate in the recognition area (around 15° - 45°) and avoids overexposure.
- Vertical Height, H: The fill light should be kept at a vertical distance of 0.5m – 0.7m away from the LPR camera.

### Typical Installation Scenario of LPR Camera



Ensure that car plate is kept close to horizontal line



Too large angle with horizontal line might lead to accuracy issues

## Setting Up SNP141

1. The factory default IP configuration for SNP141 is **192.168.1.100** (username: **admin**, Password: **MagLPR@2026**) \*Password will be "admin" once device get reset
2. Before connecting to the camera, confirm whether the IP address of the current computer and the camera IP address are in the same network segment.
3. After powering up the LPR camera, open browser and input the IP address [http://192.168.1.100 /](http://192.168.1.100/)

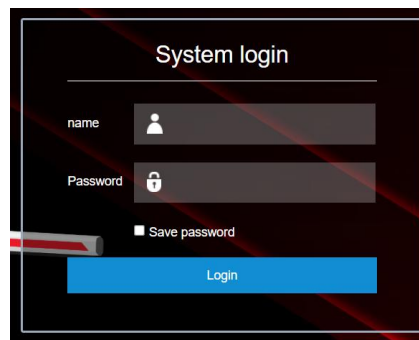

Fig. 3: Login Page

4. For first time setup using Internet Explorer browser, kindly install the plugin when the prompt pops up (not necessary for other browser types)



Fig. 4: Install plugin prompt (IE browser only)

5. Enter the default user name "admin", the default password "MagLPR@2026", and click the login button to log in. **\*Please change a stronger password for better security.**

6. After logging in, the main interface is as shown below:

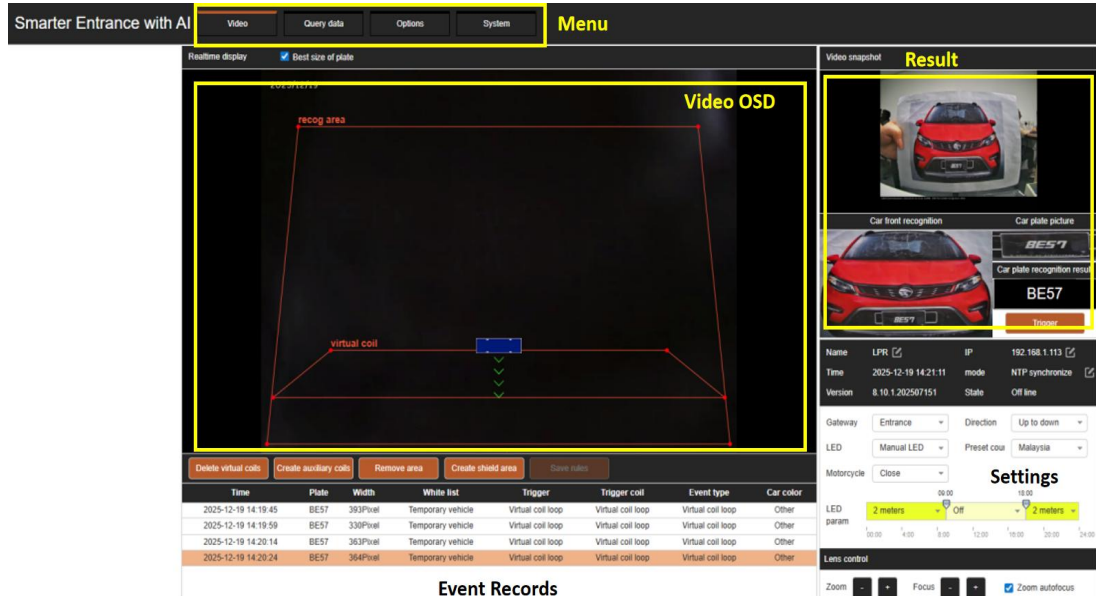

The screenshot shows the main interface of the license plate recognition system. It features a top navigation bar with 'Video', 'Query data', 'Options', 'System', and 'Menu'. The main area is divided into three sections:

- Realtime display:** Shows a video feed with a red 'recog area' and a blue 'virtual coil' loop. Below the video are buttons for 'Delete virtual coils', 'Create auxiliary coils', 'Remove area', 'Create shield area', and 'Save video'.
- Video snapshot Result:** Displays a car image with 'Car front recognition' and 'Car plate picture' (BE57). Below it, 'Car plate recognition result' shows 'BE57' and a 'Trigger' button. Metadata includes Name (LPR), IP (192.168.1.113), Time (2025-12-19 14:21:11), Version (8.10.1.202507151), and State (Off line).
- Event Records:** A table listing detected vehicles.
- Settings:** Includes 'Gateway' (Entrance), 'Direction' (Up to down), 'LED' (Manual LED), 'Preset cou' (Malaysia), 'Motorcycle' (Close), and 'LED param' (2 meters, Off, 2 meters).

Time	Plate	Width	White list	Trigger	Trigger coil	Event type	Car color
2025-12-19 14:19:45	BE57	363Pixel	Temporary vehicle	Virtual coil loop	Virtual coil loop	Virtual coil loop	Other
2025-12-19 14:19:59	BE57	330Pixel	Temporary vehicle	Virtual coil loop	Virtual coil loop	Virtual coil loop	Other
2025-12-19 14:20:14	BE57	363Pixel	Temporary vehicle	Virtual coil loop	Virtual coil loop	Virtual coil loop	Other
2025-12-19 14:20:24	BE57	364Pixel	Temporary vehicle	Virtual coil loop	Virtual coil loop	Virtual coil loop	Other

Fig. 5: Web Portal Main Page

- Select country preset according to your country (like select to "Malaysia") for accurate recognition.
- In the real-time video display, the recognition area and virtual coil loop is marked by default.
- Double-click on OSD to enter full screen mode and double-click again to exit.
- To create area, select the navigation button below OSD to create area according to type of area is needed.
- To edit the area, click somewhere within the area (the border line of area will turns to blue from red, once successfully be selected.) To remove the area, select the area and remove it via the bottom navigation button provided.
- To adjust the shape of the area, use the red points on the vertex to adjust the shape and size of the area. Multiple red points can be added and adjusted, once the point was created successfully.
- Shielded area can be used to cover up the area needed to be ignored to avoid unwanted recognition like car park area and others irrelevant vehicle lane.

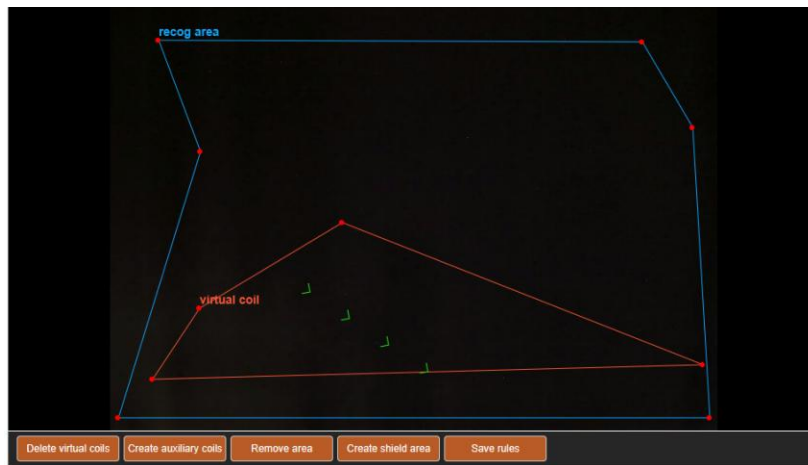

Fig. 6: Example of Configuration for Recognition Area & Virtual Coil Loop

14. After completing the adjustment, click on “Save rules” to save the configuration for both recognition area and virtual coil loop area.

**Important Note:**

**Recognition/Identification Area:** When the vehicle enters the identification area, it will start to identify and analyse the license plate.

**Virtual Coil Loop:** When the vehicle enters the virtual coil loop area (trigger area), the recognition result of the license plate will be sent.

For **6MM Prime Lens**, functions with zoom & auto-focus cannot be used since it was a fixed camera lens.

## Positioning of Virtual Coil Loop

1. When calibrating the recognition area and virtual coil loop area, you may separate the video screen into 3 segments. The Virtual Coil Loop should be positioned at the lower 3rd segment of the video height.

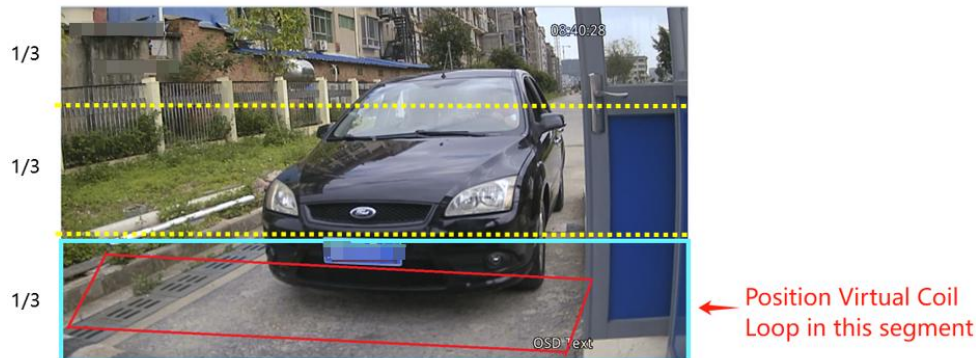

Fig. 7: Positioning of Virtual Coil Loop

2. Ensure that the left and right area of the Virtual Coil Loop is able to cover the car license plate.

## Recognition Area Full Coverage

1. When calibrating the recognition area, make sure to include the effective range of movement of the license plate on the screen.



Fig. 8: Recognition Area Adjustment according to Site

2. When calibrating the recognition area, ensure more area is included for the vehicle to gain more video streams and more recognition frames for better accuracy.

## Event Capture

1. After completing the LPR calibrations, incoming vehicle car plates will be captured automatically and the identified license plate number will be displayed on the right side.

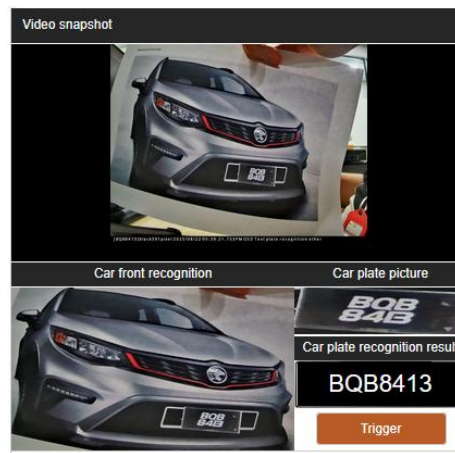

Fig. 9: Car Plate Identification Result

2. To manually trigger the car plate recognition, click on the “Trigger” button to manually capture a test image. The captured image will automatically display the close-up car image and the license plate, whereas the license plate number identified will be displayed on the right side.
3. Under the real-time display interface, there is a snapshot event history of all the car plates identified.

Time	Plate	Width	White list	Trigger	Trigger coil	Event type
2025-08-22 17:39:11	BQB8413	523Pixel	Temporary vehicle	Virtual coil loop	Virtual coil loop	Virtual coil loop
2025-08-22 17:39:12	BQB843	419Pixel	Temporary vehicle	Virtual coil loop	Virtual coil loop	Virtual coil loop
2025-08-22 17:39:15	BQB8413	490Pixel	Temporary vehicle	Virtual coil loop	Virtual coil loop	Virtual coil loop
2025-08-22 17:39:21	BQB8413	391Pixel	Temporary vehicle	Virtual coil loop	Virtual coil loop	Virtual coil loop

Fig. 10: Identified Car Plate Event Log

## Device Settings

At the top of the interface, click on Options to enter the advanced setting menu as shown below:

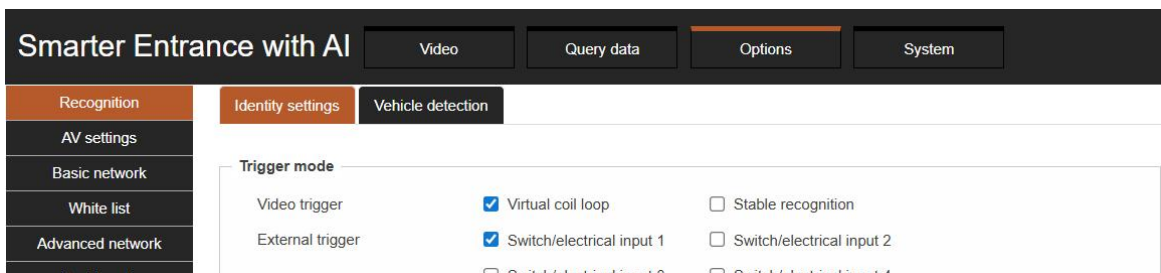

Fig. 11: Advance Setting Interface

## Recognition/ Identification Setting

1. Use the Trigger Mode to switch between different types of identification trigger.
2. Recognition parameters can be used to change image resolution, image quality, result delay, car plate pixel limit and same plate trigger intervals.

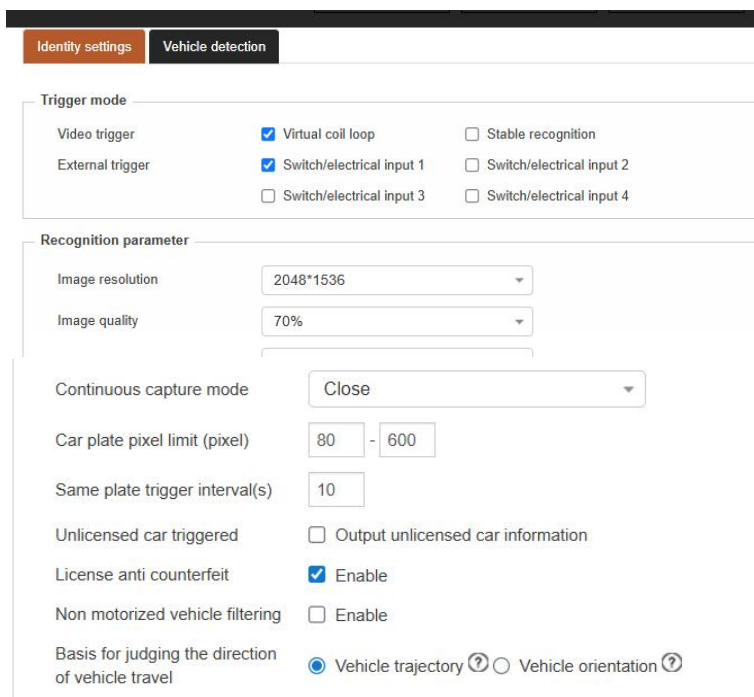

Fig. 12: Identification Setting Interface

## Basic Network Settings

In the basic setting tab, you may configure the basic network settings as follows:

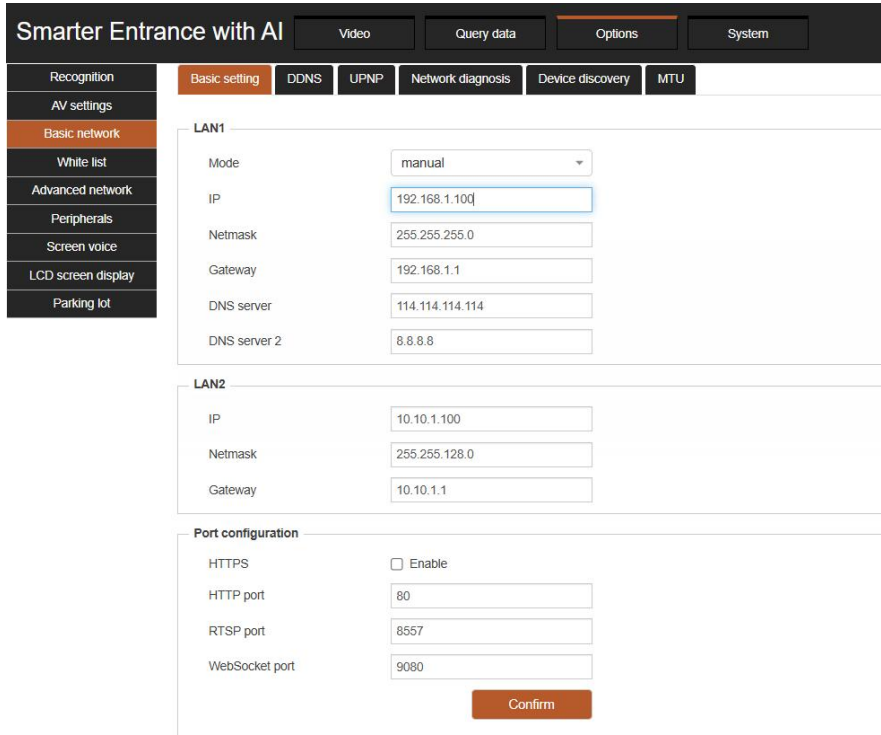

Fig. 13: Basic Network Settings

- **IP:** To configure the network IP address.
- **Netmask:** To configure the subnet mask of the network.
- **Gateway:** To configure the network default gateway. It should be in the same network segment as the IP address
- **DNS server:** To configure the DNS server of the network. After configuring the network parameters, click OK to take effect.
- **DNS server 2:** To configure the standby DNS server, and automatically switch to this DNS server when there is connection error in the default DNS server
- **HTTP port:** To configure the port number of HTTP protocol. The default is 80. Click confirm button to take effect.
- **RTSP port:** To configure the port number of RTSP video stream. The default is 8557. Click confirm button to take effect.
- **WebSocket port:** To configure full duplex real time communication, 9080 as default. Click confirm button to take effect.

## White List

In the white list configuration tab, you may configure white list as follows:

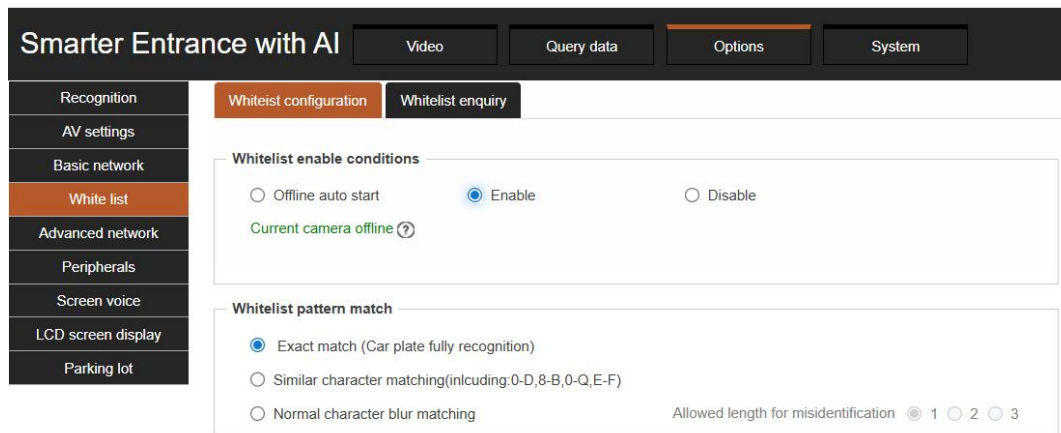

Fig. 14: Whitelist Configuration Settings

- Whitelist enable conditions: To enable the working condition for car plate whitelist
- Whitelist pattern match: Accuracy of car plate pattern match can be set according to actual use case.

### Important Note:

If SNP141 is using ME-ACS, all number plates will be uploaded to the whitelist using ME-ACS features. Similarly, if you want to delete a plate number from the whitelist, it may require the ME-ACS software.

## Peripherals

- In the peripheral settings, you may set the output configuration as below:

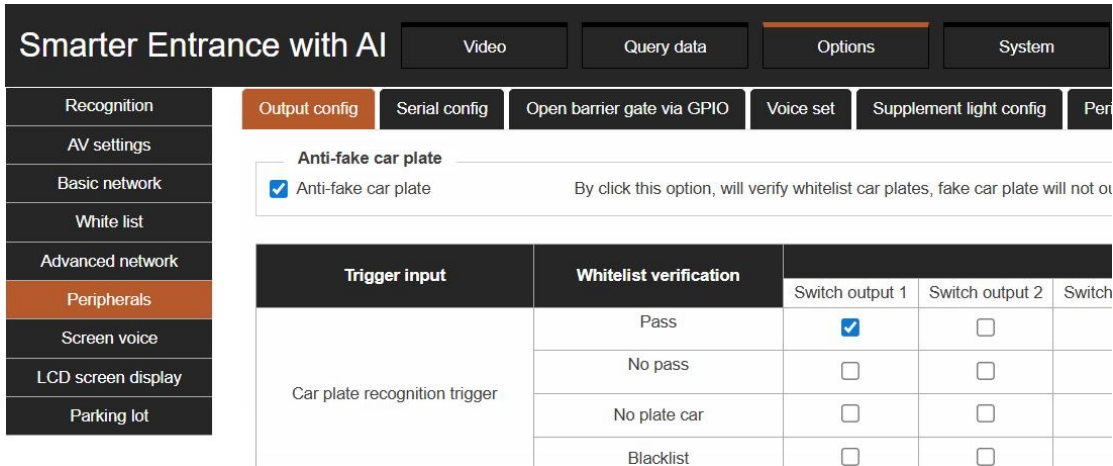

Smarter Entrance with AI

Video Query data Options System

Recognition AV settings Basic network White list Advanced network **Peripherals** Screen voice LCD screen display Parking lot

Output config Serial config Open barrier gate via GPIO Voice set Supplement light config Per

Anti-fake car plate

Anti-fake car plate By click this option, will verify whitelist car plates, fake car plate will not ou

Trigger input	Whitelist verification	Switch		
		Switch output 1	Switch output 2	Switch
Car plate recognition trigger	Pass	<input checked="" type="checkbox"/>	<input type="checkbox"/>	
	No pass	<input type="checkbox"/>	<input type="checkbox"/>	
	No plate car	<input type="checkbox"/>	<input type="checkbox"/>	
	Blacklist	<input type="checkbox"/>	<input type="checkbox"/>	

Fig. 15: Output Configuration

- Anti-fake car plate: When the opening function is enabled, the fake license plate will not trigger the output linkage control.
  - When the license plate recognition is triggered, the user can configure the system to output signals at various ports according to the white list verification.
  - Users can configure the system to trigger multiple (only partial output ports) output port signals when obtaining input port signals.
- In the LED configuration tab, you may configure the LED fill light settings as below:

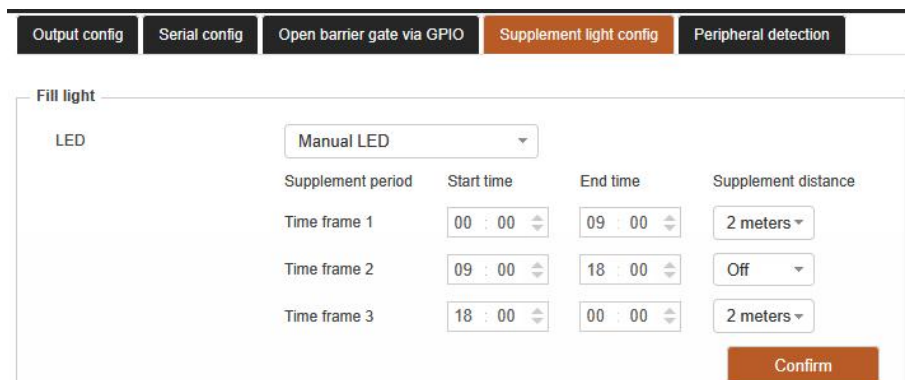

Output config Serial config Open barrier gate via GPIO **Supplement light config** Peripheral detection

Fill light

LED Manual LED

Supplement period	Start time	End time	Supplement distance
Time frame 1	00 : 00	09 : 00	2 meters
Time frame 2	09 : 00	18 : 00	Off
Time frame 3	18 : 00	00 : 00	2 meters

Confirm

Fig. 18: LED Fill Light Configuration

- **Fill light mode:** Select the working state of fill light.

- For manual LED mode, You can set the LED fill light configuration in different time periods by adjusting the time periods and LED installation distance.
3. After setting up all IO connections, you may use the peripheral detection tab to check the connection status of the ports as shown below:

IO	Status	Operation
Switch/electrical input 1	1	<input type="button" value="Get"/>
Switch/electrical input 2	1	<input type="button" value="Get"/>
Switch/electrical input 3	1	<input type="button" value="Get"/>
Switch/electrical input 4	1	<input type="button" value="Get"/>
Switch output 1	0	<input type="text" value="0"/>
Switch output 2	0	<input type="text" value="0"/>
Switch output 3	0	<input type="text" value="0"/>
Switch output 4	0	<input type="text" value="0"/>

Fig. 19: Peripheral Detection

- In the input port section, click the get button to get the current port connectivity status.
- In the output port section, select the path/open option to set the current port status to turn on/off.

## LED Screen Display Setting

In the screen voice tab, you may configure the LED screen display as below:

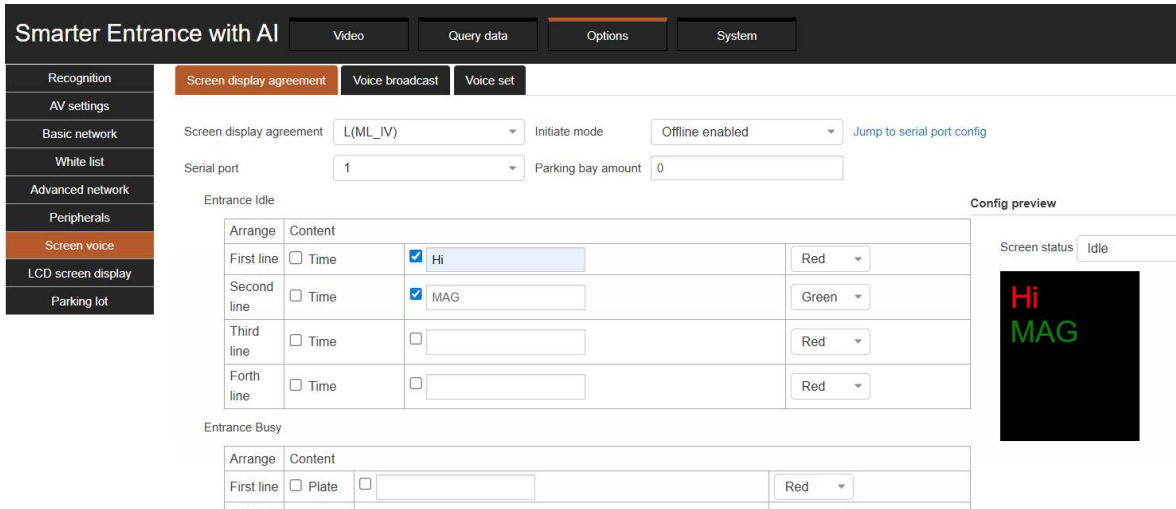

The screenshot shows the 'Smarter Entrance with AI' configuration interface. The 'Options' tab is selected, and the 'Screen display agreement' sub-tab is active. The configuration includes:

- Screen display agreement:** L(ML\_IV)
- Initiate mode:** Offline enabled
- Serial port:** 1
- Parking bay amount:** 0
- Entrance Idle configuration:**

Arrange	Content	Color
First line	<input type="checkbox"/> Time <input checked="" type="checkbox"/> Hi	Red
Second line	<input type="checkbox"/> Time <input checked="" type="checkbox"/> MAG	Green
Third line	<input type="checkbox"/> Time <input type="checkbox"/> [ ]	Red
Fourth line	<input type="checkbox"/> Time <input type="checkbox"/> [ ]	Red
- Entrance Busy configuration:**

Arrange	Content	Color
First line	<input type="checkbox"/> Plate <input type="checkbox"/> [ ]	Red
- Config preview:** Shows a preview of the screen status as 'Idle' with the text 'Hi' in red and 'MAG' in green.

Fig. 20: LED Screen Display Configuration

- According to the screen display agreement, select model = L(ML\_IV) for SNP141-DSP MAG Two lines LED Display.
- For serial port connection, select 1 for RS485-1 (Port 1) while 2 for RS485-2 (Port 2).
- Screen display can be set with both idle and busy condition, content of idle can be selected along with time, while car license plate can be showed along with content under busy condition.
- Select a time for traffic light delay for every first time screen display agreement configuration.
- Click the confirm button to save the configuration.

## Wiring Connection

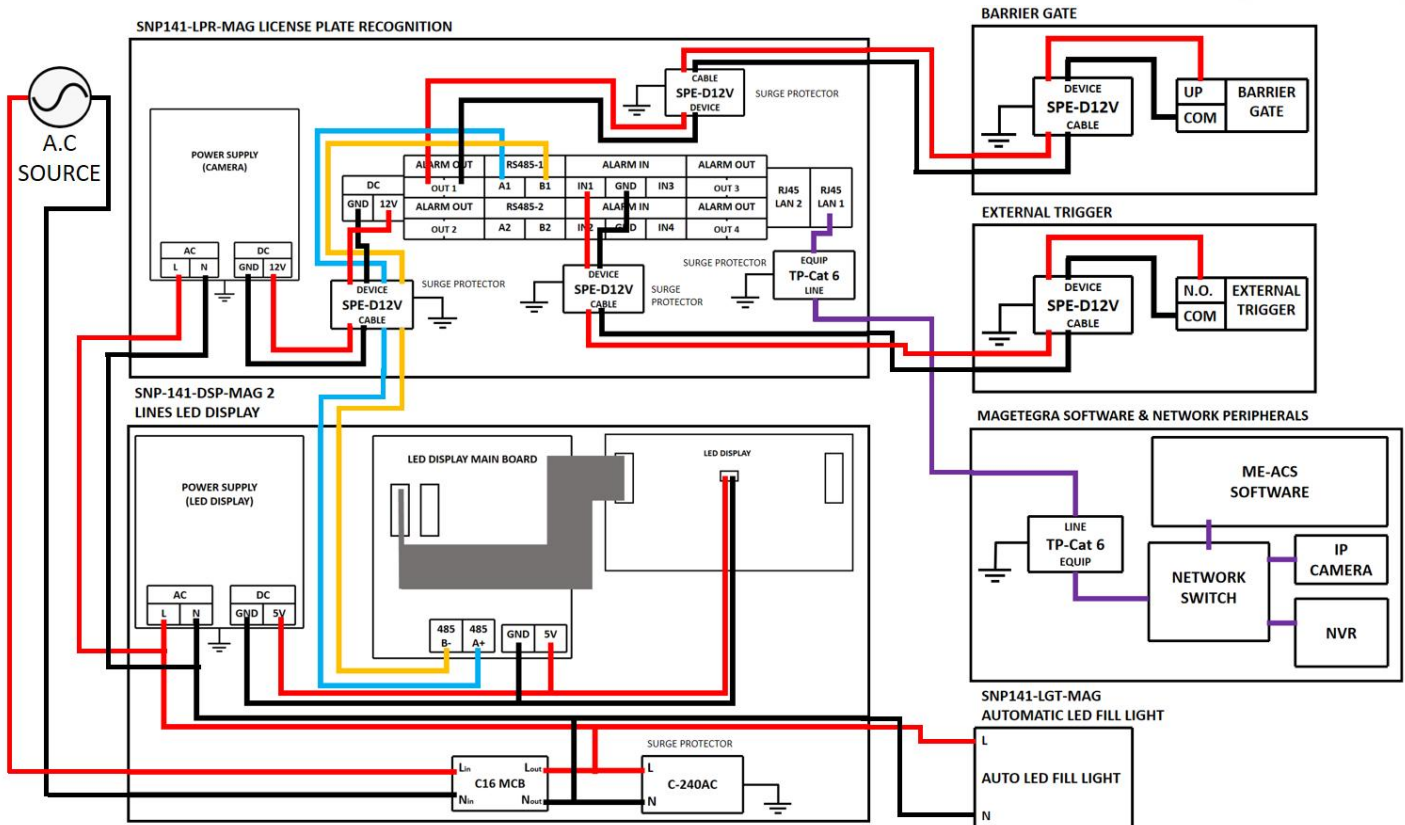

Fig. 21: Wiring Diagram

### Important Notes:

- IP address of the SNP141 has to be same network as ME-ACS software.
- LED Display SNP141-DSP, (A1 & B1) have to be fully connected accordingly and the agreement of L(ML\_IV) is choose to ensure that is the same captured license plate from camera to be displayed on LED display as expected.
- For SNP141 to control barrier gate, output terminal connection likes Alarm Out (OUT1) have to be connected to UP terminal of the Barrier Gate.
- SNP141 can have external trigger to capture license plate and this is optional connection. This is commonly used for Loop Coil Detector.
- Surge protector is essential to protect electronic equipment from damaging power surges by diverting excessive voltage from a lightning strike or other electrical anomaly to the ground.

\*Product performances is based on testing in a controlled environment. Your result may vary due to several external and environment factors.

© COPYRIGHT 2026. This documentation served as a reference only. It is subject to change without further notice. All the diagrams and information in this documentation may not be duplicated or modified in any form without the written approval from the management.

